



Statement of Verification

BREG EN EPD No: 000791

Issue: 01

This is to verify that the Environmental Product Declaration provided by:

Sheerline Ltd

are in accordance with the requirements of:

EN 15804:2012+A2:2019

and

BRE Global Scheme Document SD207

This declaration is for:

1 kg of Sheerline windows, door and roofing profiles

Company Address

Sheerline Ltd
Firs Works,
Spanker Lane,
Nether Heage,
Belper, Derbyshire,
DE56 2JJ

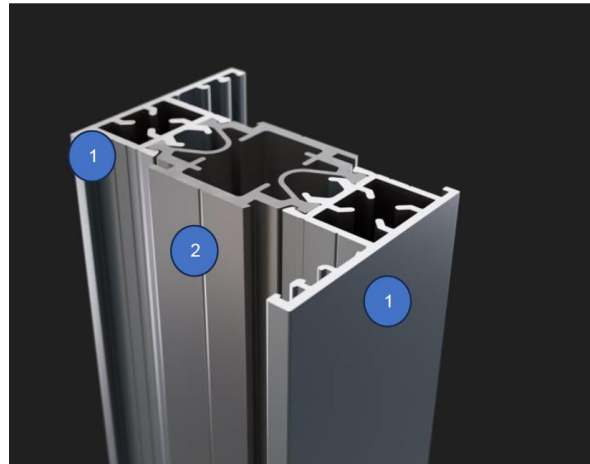

Signed for BRE Global Limited

Hayley Thomson

Operator

26 May 2026

Date of this Issue

26 May 2026

Date of First Issue

25 May 2031

Expiry Date



This Statement of Verification is issued subject to terms and conditions (for details visit www.greenbooklive.com/terms).

To check the validity of this statement of verification please, visit www.greenbooklive.com/check or contact us.

BRE Global Ltd., Garston, Watford WD25 9XX
T: +44 (0)333 321 8811 F: +44 (0)1923 664603 E: Enquiries@breglobal.com





Environmental Product Declaration

EPD Number: 000791

General Information

EPD Programme Operator	Applicable Product Category Rules
BRE Global Watford, Herts WD25 9XX United Kingdom	BRE Environmental Profiles 2025 Product Category Rules for Type III environmental product declaration of construction products to EN 15804+A2 PN 514 Rev 3.2
Commissioner of LCA study	LCA consultant/Tool
Sheerline Ltd Firs Works, Spanker Lane, Nether Heage, Belper, Derbyshire, DE56 2JJ	Chi Zhang / BRE LINA2.0
Declared/Functional Unit	Applicability/Coverage
1 kg of Sheerline windows, door and roofing profiles	Product Specific
EPD Type	Background database
Cradle to Gate with Module C and D	Ecoinvent 3.8

Demonstration of Verification

CEN standard EN 15804 serves as the core PCR ^a

Independent verification of the declaration and data according to EN ISO 14025:2010

Internal

External

(Where appropriate ^b) Third party verifier:

Kim Allbury

a: Product category rules

b: Optional for business-to-business communication; mandatory for business-to-consumer communication (see EN ISO 14025:2010, 9.4)

Comparability

Environmental product declarations from different programmes may not be comparable if not compliant with EN 15804:2012+A2:2019. Comparability is further dependent on the specific product category rules, system boundaries and allocations, and background data sources. See Clause 5.3 of EN 15804:2012+A2:2019 for further guidance



Information modules covered

Product			Construction		Use stage							End-of-life				Benefits and loads beyond the system boundary
A1	A2	A3	A4	A5	Related to the building fabric					Related to the building						D
					B1	B2	B3	B4	B5	B6	B7	C1	C2	C3	C4	
Raw materials supply	Transport	Manufacturing	Transport to site	Construction – Installation	Use	Maintenance	Repair	Replacement	Refurbishment	Operational energy use	Operational water use	Deconstruction demolition	Transport	Waste processing	Disposal	Reuse, Recovery and/or Recycling potential
<input checked="" type="checkbox"/>	<input checked="" type="checkbox"/>	<input checked="" type="checkbox"/>	<input type="checkbox"/>	<input type="checkbox"/>	<input type="checkbox"/>	<input type="checkbox"/>	<input type="checkbox"/>	<input type="checkbox"/>	<input type="checkbox"/>	<input type="checkbox"/>	<input type="checkbox"/>	<input checked="" type="checkbox"/>	<input checked="" type="checkbox"/>	<input checked="" type="checkbox"/>	<input checked="" type="checkbox"/>	<input checked="" type="checkbox"/>

Note: Ticks indicate the Information Modules declared.

Manufacturing site(s)

Firs Works

Spanker Lane,
Nether Heage,
Belper,
Derbyshire,
DE56 2JJ

Construction Product:

Product Description

Sheerline is the innovative award-winning brand of aluminium windows, doors, and roof systems designed, developed, and extruded by Garner Aluminium Extrusions (Garnalex). Profiles are powder-coated in-house in a range of standard and special colours or woodgrain foiled for an authentic wood-effect look.

The profiles are highly thermally efficient due to Garnalex's proprietary thermal technology, Thermlock®, which has been recognised with a King's Award for Innovation 2025. This technology enables Sheerline to offer high-performance U-values across the entire product range.

Homeowners cannot buy from Sheerline directly, but through its network of trusted fabricator partners. 6m lengths of profile are supplied to fabricators who then make the finished windows, doors, and roof systems for installation at their customers' premises. Only lengths of profile and accessories are supplied.

uPVC gaskets are included within the scope of the EPD as they are manufactured on the main factory site as part of the same production process. Glass units are not included within the scope of the EPD as they are sourced by the fabricator and fitted at the point of installation.

The image in Technical Information shows how profile is supplied to customers after assembly. It consists of two lengths of powder coated aluminium (1) joined in the middle by a uPVC thermal break (2). Both products are manufactured on the main factory site.

All sizes of Sheerline products comply with the same manufacturing process and material composition, however, this EPD only measured the impact of 1kg of the Sheerline windows, doors, and roof system profiles.

Technical Information

Property	Value, Unit
BS EN 755-9:2016 Aluminium and Aluminium alloys	Conforms
BS4873:2016 Aluminium alloy windows	Conforms
BS4873:2016 & PAS24:2022 Enhanced security performance requirements for window assemblies	Conforms
BS4873:2016 & PAS24:2022 Enhanced security aluminium door systems	Conforms
uPVC thermal breaks to have an end reversion	≤ 2.0%
uPVC compound density	1.43 g/m ³

Note: More technical information available in Sheerline aluminium windows and doors website:
<https://www.sheerline.com/product/specifiersinfo/>

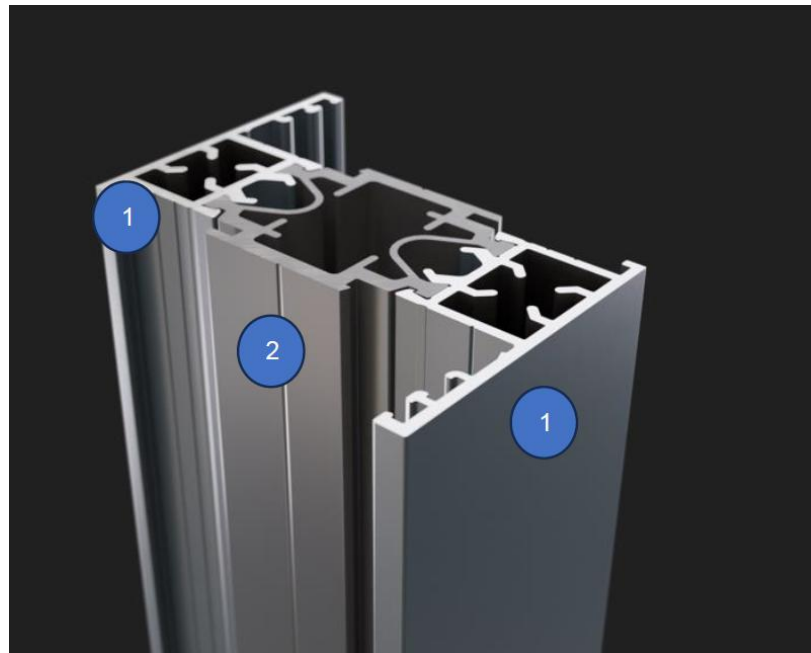

Main Product Contents



Material/Chemical Input	%
Aluminium	73
uPVC	24
Polyester powder paint	3

Note: The above main product content is for all Sheerline windows, door and roofing profiles.

Manufacturing Process

The manufacturing process begins with the Aluminium production process. Raw material – Al6063 aluminium logs is delivered, heated to 500°C, and pressed through pre-heated dies to produce mill-finished products. Following annealing process, aged at 195°C for five hours, then they are prepared and packaged for powder coating.

In powder coating process, polyester powder paint is received. Mill-finished products are subjects to a 7 stage, chrome free pre-treatment process, then powder coated and subject to 30 mins of curing in oven at 195°C. The Coated products are inspected and packaged into stillages.

At the same time, uPVC thermal breaks and gaskets are produced. uPVC compounds are delivered, extruded, and packed.

Finally, in the assembly stage, the painted aluminium and uPVC thermal breaks are combined to make finished profiles for windows, doors and roofs. These are then packed and delivered to customers using Sheerline’s own transport (this transport is not measured in the LCA analysis).

Throughout the process, manufacturing scrap and billet ends are returned to the aluminium smelter for recycling. This material is considered internal / pre-consumer scrap and, in accordance with ISO 14021, has not been counted as recycled content within the LCA.

Electricity from UK national grid is used in powering machinery and plant, and liquefied petroleum gas (LPG) is used for pre-heating aluminium logs, annealing process and paint curing.



Process flow diagram



Sheerline Manufacturing Process Flowchart (for EPD)

Painted and thermally broken aluminium window, roof & door systems

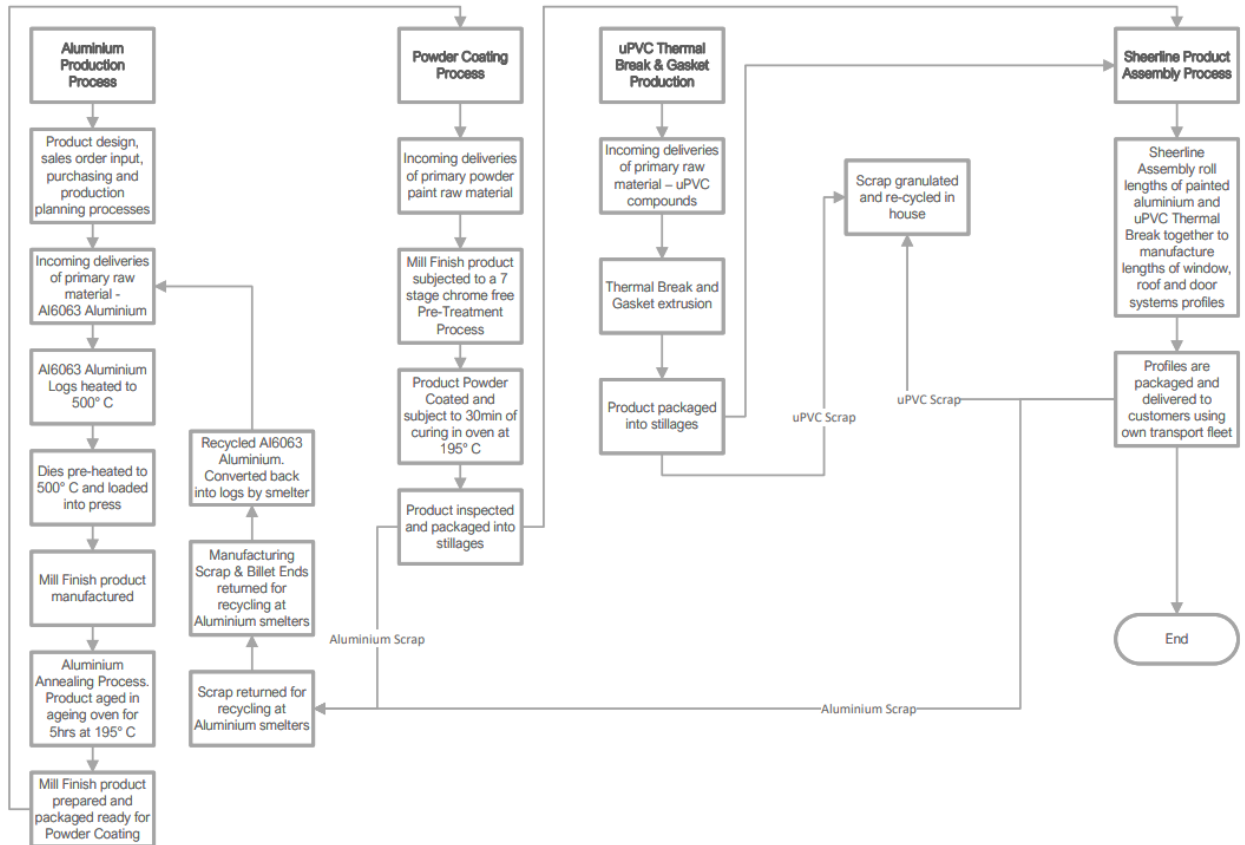

Transport to site and construction – installation (A4 – A5)

Module A4 (transport to site) and A5 (construction-installation) are not declared in this EPD.



The product is packaged with twin wall cardboard, polythene sheet and bubble wrap as shown below:

Packaging material	Mass per DU (kg)	Biogenic carbon (kg C per DU)
Twin wall cardboard	4.67×10^{-2}	2.10×10^{-2}
Polythene sheet	7.74×10^{-3}	0.00
Bubble wrap	1.76×10^{-2}	0.00
Total	7.20×10^{-2}	2.10×10^{-2}

A standard UK disposal scenario has been applied based on DEFRA data (UK Statistics on Waste, 2025, Methodology 1 – provisional 2024 figures):

- Cardboard: 74.3% recycled, the remainder sent to energy recovery or landfill
- Polythene sheet & bubble wrap: 51% recycled (overall plastic packaging rate), the remainder sent to energy recovery or landfill

The biogenic carbon in the cardboard would be released in module A5 when the packaging is thrown away on site. The biogenic carbon content is shown in the table above for transparency. Polythene and bubble wrap carry no biogenic carbon.

End of Life

At end-of-life during the deconstruction phase, the installer removes the window or door system from the property prior to replacement. Hand power tools are used to dismantle the Sheerline frames, electricity used to charge power tool batteries, which is considered negligible in comparison with the overall energy demand of building demolition. The product is then transported to the recycling and incineration facility, as per the end-of-life scenario for {window frame, aluminium} and {window frame, PVC/uPVC} stated in Appendix D of the BRE PCR document, using a generic transportation distance of 50 km. End-users of the EPD can use the Module C2 results to calculate a bespoke transport distance if required (divide results by 50 and multiply by required distance in km). The coated aluminium contains 25.9% of pre-existing secondary content that has been removed from the Module D calculation to avoid the double-counting of environmental benefits.



Life Cycle Assessment Calculation Rules

Declared unit description

1 kg of Sheerline windows, door and roofing profiles

System boundary

In accordance with the modular approach as defined in EN15804:2012 + A2:2019 and the BRE 2025 Product Category Rules (PN 524 Rev 3.2), this cradle-to-gate with modules C and D EPD includes the processes covered during the raw material extraction and manufacturing phase in modules A1 to A3, and the end-of-life scenario in modules C1, C2, C3, C4 and module D.

Data sources, quality and allocation

Specific primary data derived from Sheerline Ltd have been modelled using the LINA A2 tool for the period 01/01/2023 – 31/12/2023. In accordance with the requirements of EN15804, the most current available data have been used. Secondary data have been obtained for all remaining upstream and downstream processes that are beyond the control of the manufacturer from the ecoinvent 3.8 database, applying the "Cut-off, EN 15804" system model.

Impact category results have been calculated using the characterisation factors specified in Annex C of EN 15804:2012+A2:2019, based on the Environmental Footprint (EF) 3.0 method. All ecoinvent datasets are complete within the context used and conform to the system boundary and the criteria for the exclusion of inputs and outputs, according to the requirements specified in EN15804+A2:2019.

The Sheerline Window, Door and Roofing profiles are not the only products manufactured at the Firs Works factory. A physical allocation by mass(kg) of the site process data has therefore been carried out, according to EN 15804 and ISO 14044 guidance, to determine the correct quantities of energy, packaging, water and non-production waste attributable to the Sheerline Window, Door and Roofing profiles production. This is because energy consumption and emissions are considered proportional to the mass of product throughput. And raw materials, ancillary materials, production wastes and wastewater are actual usage, based on bills and records.

The mass balance for the Sheerline Window, Door and Roofing profiles was within tolerance.

Data Quality Assessment:

The quality of the data used in this EPD has been assessed in accordance with Table E.1 of Annex E in BS EN 15804:2012+A2:2019, covering geographical, technical and time representativeness.

Quality Level	Geographical representativeness	Technical representativeness	Time representativeness
Good	Data from area under study.	Data from processes and products under study. Same state of technology applied as defined in goal and scope (i.e., identical technology).	There is approximately 3 years between the Ecoinvent LCI reference year, and the time period for which the LCA was undertaken.

The quality level of geography, time and technological representativeness is good as specific datasets have been selected from the ecoinvent LCI, the background LCI datasets are from ecoinvent v3.8 which was compiled in 2021, and manufacturer-specific primary data has been modelled. Therefore, the most appropriate LCA data have been used. The GWP of the electricity dataset used for this EPD is: 1 kWh UK electricity = 0.239 kgCO₂eq (Electricity GB (kWh) market for electricity, medium voltage). This is a 2022 UK consumption (or location-based) electricity mix dataset. The GWP of the liquefied petroleum gas dataset used for this EPD is: 1 kg liquefied petroleum gas = 0.606 kg CO₂eq (Liquefied petroleum gas production, Rest of World).



Cut-off criteria

All raw materials, ancillary materials, packaging, energy, water, waste and processes associated with the manufacturing process have been included, except for direct emissions to air, water and soil, which are not measured.

LCA Results

(MND = module not declared; MNR = module not relevant; INA = indicator not assessed; AGG = aggregated)

Parameters describing environmental impacts			GWP-total	GWP-fossil	GWP-biogenic	GWP-luluc	ODP	AP	EP-freshwater
			kg CO ₂ eq	kg CO ₂ eq	kg CO ₂ eq	kg CO ₂ eq	kg CFC11 eq	mol H ⁺ eq	kg (PO ₄) ³⁻ eq
Product stage	Raw material supply	A1	7.55E+00	7.51E+00	2.59E-02	1.68E-02	6.39E-07	4.43E-02	2.87E-03
	Transport	A2	1.63E-02	1.63E-02	1.39E-05	6.39E-06	3.77E-09	6.61E-05	1.05E-06
	Manufacturing	A3	7.03E-01	5.76E-01	1.26E-01	6.67E-04	9.49E-08	1.97E-03	1.02E-04
	Total	A1-3	8.27E+00	8.10E+00	1.52E-01	1.75E-02	7.38E-07	4.64E-02	2.97E-03
End of life	Deconstruction, demolition	C1	0.00E+00	0.00E+00	0.00E+00	0.00E+00	0.00E+00	0.00E+00	0.00E+00
	Transport	C2	8.32E-03	8.31E-03	7.08E-06	3.26E-06	1.92E-09	3.37E-05	5.35E-07
	Waste processing	C3	7.12E-01	7.10E-01	2.37E-03	3.42E-04	2.94E-08	1.28E-03	7.88E-05
	Disposal	C4	1.50E-03	1.48E-03	1.34E-05	1.66E-06	1.62E-10	9.84E-06	4.37E-07
Potential benefits and loads beyond the system boundaries	Reuse, recovery, recycling potential	D	-1.16E+01	-1.16E+01	3.20E-02	-1.55E-02	-3.48E-07	-7.43E-02	-3.50E-03

GWP-total = Global warming potential, total;
 GWP-fossil = Global warming potential, fossil;
 GWP-biogenic = Global warming potential, biogenic;
 GWP-luluc = Global warming potential, land use and land use change;

ODP = Depletion potential of the stratospheric ozone layer;
 AP = Acidification potential, accumulated exceedance; and
 EP-freshwater = Eutrophication potential, fraction of nutrients reaching freshwater end compartment



LCA Results

(MND = module not declared; MNR = module not relevant; INA = indicator not assessed; AGG = aggregated)

Parameters describing environmental impacts			EP-marine	EP-terrestrial	POCP	ADP-mineral&metals	ADP-fossil	WDP	PM
			kg N eq	mol N eq	kg NMVOC eq	kg Sb eq	MJ, net calorific value	m ³ world eq deprived	disease incidence
Product stage	Raw material supply	A1	7.68E-03	7.90E-02	2.48E-02	9.97E-05	9.20E+01	2.81E+00	1.06E-06
	Transport	A2	1.99E-05	2.17E-04	6.66E-05	5.66E-08	2.46E-01	1.11E-03	1.41E-09
	Manufacturing	A3	4.80E-04	4.50E-03	1.43E-03	5.24E-06	1.28E+01	1.37E-01	1.90E-08
	Total	A1-3	8.18E-03	8.37E-02	2.63E-02	1.05E-04	1.05E+02	2.95E+00	1.08E-06
End of life	Deconstruction, demolition	C1	0.00E+00	0.00E+00	0.00E+00	0.00E+00	0.00E+00	0.00E+00	0.00E+00
	Transport	C2	1.02E-05	1.11E-04	3.40E-05	2.89E-08	1.26E-01	5.65E-04	7.17E-10
	Waste processing	C3	2.68E-04	2.74E-03	7.76E-04	9.48E-06	2.37E+00	9.72E-01	1.72E-08
	Disposal	C4	2.44E-06	2.62E-05	7.79E-06	3.28E-09	2.11E-02	6.68E-04	1.47E-10
Potential benefits and loads beyond the system boundaries	Reuse, recovery, recycling potential	D	-1.24E-02	-1.29E-01	-3.72E-02	-9.99E-06	-1.05E+02	-1.42E+00	-9.53E-07

EP-marine = Eutrophication potential, fraction of nutrients reaching marine end compartment;
 EP-terrestrial = Eutrophication potential, accumulated exceedance;
 POCP = Formation potential of tropospheric ozone;
 ADP-mineral&metals = Abiotic depletion potential for non-fossil resources;

ADP-fossil = Depletion potential of the stratospheric ozone layer;
 WDP = Water (user) deprivation potential, deprivation-weighted water consumption; and
 PM = Particulate matter.



LCA Results

(MND = module not declared; MNR = module not relevant; INA = indicator not assessed; AGG = aggregated)

Parameters describing environmental impacts			IRP	ETP-fw	HTP-c	HTP-nc	SQP
			kBq U ²³⁵ eq	CTUe	CTUh	CTUh	dimensionless
Product stage	Raw material supply	A1	6.27E-01	1.98E+02	1.41E-08	1.78E-07	1.84E+01
	Transport	A2	1.27E-03	1.92E-01	6.22E-12	2.01E-10	1.69E-01
	Manufacturing	A3	2.13E-01	8.67E+00	2.42E-10	6.59E-09	5.28E+00
	Total	A1-3	8.41E-01	2.07E+02	1.43E-08	1.84E-07	2.38E+01
End of life	Deconstruction, demolition	C1	0.00E+00	0.00E+00	0.00E+00	0.00E+00	0.00E+00
	Transport	C2	6.46E-04	9.81E-02	3.18E-12	1.03E-10	8.63E-02
	Waste processing	C3	2.05E-02	3.22E+01	2.43E-10	1.36E-08	1.92E+00
	Disposal	C4	1.23E-04	2.36E+01	1.38E-12	3.64E-11	2.70E-02
Potential benefits and loads beyond the system boundaries	Reuse, recovery, recycling potential	D	-1.70E-01	-2.97E+02	-1.19E-08	-2.54E-07	-2.21E+01

IRP = Potential human exposure efficiency relative to U235;
 ETP-fw = Potential comparative toxic unit for ecosystems;
 HTP-c = Potential comparative toxic unit for humans;

HTP-nc = Potential comparative toxic unit for humans; and
 SQP = Potential soil quality index.



LCA Results

(MND = module not declared; MNR = module not relevant; INA = indicator not assessed; AGG = aggregated)

			Parameters describing resource use, primary energy					
			PERE	PERM	PERT	PENRE	PENRM	PENRT
			MJ	MJ	MJ	MJ	MJ	MJ
Product stage	Raw material supply	A1	9.17E+00	0.00E+00	9.17E+00	8.41E+01	7.13E+00	9.12E+01
	Transport	A2	3.47E-03	0.00E+00	3.47E-03	2.42E-01	0.00E+00	2.42E-01
	Manufacturing	A3	-7.14E-02	1.92E+00	1.85E+00	7.75E+00	6.31E+00	1.41E+01
	Total	A1-3	9.10E+00	1.92E+00	1.10E+01	9.21E+01	1.34E+01	1.06E+02
End of life	Deconstruction, demolition	C1	0.00E+00	0.00E+00	0.00E+00	0.00E+00	0.00E+00	0.00E+00
	Transport	C2	1.77E-03	0.00E+00	1.77E-03	1.23E-01	0.00E+00	1.23E-01
	Waste processing	C3	2.06E-01	0.00E+00	2.06E-01	3.36E+00	5.05E+00	1.69E+00
	Disposal	C4	1.36E-03	0.00E+00	1.36E-03	2.09E-02	0.00E+00	2.09E-02
Potential benefits and loads beyond the system boundaries	Reuse, recovery, recycling potential	D	-6.61E+00	0.00E+00	6.61E+00	1.05E+02	0.00E+00	-1.05E+02

PERE = Use of renewable primary energy excluding renewable primary energy used as raw materials;
 PERM = Use of renewable primary energy resources used as raw materials;
 PERT = Total use of renewable primary energy resources;

PENRE = Use of non-renewable primary energy excluding non-renewable primary energy resources used as raw materials;
 PENRM = Use of non-renewable primary energy resources used as raw materials;
 PENRT = Total use of non-renewable primary energy resource



LCA Results

(MND = module not declared; MNR = module not relevant; INA = indicator not assessed; AGG = aggregated)

Parameters describing resource use, secondary materials and fuels, use of water			SM	RSF	NRSF	FW
			kg	MJ net calorific value	MJ net calorific value	m ³
Product stage	Raw material supply	A1	2.43E-01	0.00E+00	0.00E+00	7.04E-02
	Transport	A2	0.00E+00	0.00E+00	0.00E+00	2.74E-05
	Manufacturing	A3	4.68E-02	4.67E-06	0.00E+00	4.16E-03
	Total	A1-3	2.90E-01	4.67E-06	0.00E+00	7.46E-02
End of life	Deconstruction, demolition	C1	0.00E+00	0.00E+00	0.00E+00	0.00E+00
	Transport	C2	0.00E+00	0.00E+00	0.00E+00	1.40E-05
	Waste processing	C3	0.00E+00	0.00E+00	0.00E+00	2.27E-02
	Disposal	C4	0.00E+00	0.00E+00	0.00E+00	1.62E-05
Potential benefits and loads beyond the system boundaries	Reuse, recovery, recycling potential	D	0.00E+00	0.00E+00	0.00E+00	-3.81E-02

SM = Use of secondary material;
RSF = Use of renewable secondary fuels;

NRSF = Use of non-renewable secondary fuels;
FW = Net use of fresh water



LCA Results

(MND = module not declared; MNR = module not relevant; INA = indicator not assessed; AGG = aggregated)

Other environmental information describing waste categories					
			HWD	NHWD	RWD
			kg	kg	kg
Product stage	Raw material supply	A1	1.22E+00	1.24E+01	2.22E-04
	Transport	A2	2.71E-04	4.82E-03	1.67E-06
	Manufacturing	A3	2.84E-02	6.66E-01	7.94E-05
	Total	A1-3	1.25E+00	1.30E+01	3.03E-04
End of life	Deconstruction, demolition	C1	0.00E+00	0.00E+00	0.00E+00
	Transport	C2	1.39E-04	2.46E-03	8.50E-07
	Waste processing	C3	1.44E-01	6.55E-01	7.52E-06
	Disposal	C4	5.78E-04	4.14E-02	8.36E-08
Potential benefits and loads beyond the system boundaries	Reuse, recovery, recycling potential	D	-2.28E+00	-1.47E+01	-1.28E-04

HWD = Hazardous waste disposed;
 NHWD = Non-hazardous waste disposed;
 RWD = Radioactive waste disposed



LCA Results (continued)

(MND = module not declared; MNR = module not relevant; INA = indicator not assessed; AGG = aggregated)

Other environmental information describing output flows – at end of life								
			CRU	MFR	MER	EE	Biogenic carbon (product)	Biogenic carbon (packaging)
			kg	kg	kg	MJ per energy carrier	kg C	kg C
Product stage	Raw material supply	A1	0.00E+00	1.55E-03	2.89E-06	0.00E+00	0.00E+00	0.00E+00
	Transport	A2	0.00E+00	0.00E+00	0.00E+00	0.00E+00	0.00E+00	0.00E+00
	Manufacturing	A3	0.00E+00	2.64E-02	3.85E-08	3.73E-03	0.00E+00	2.10E-02
	Total	A1-3	0.00E+00	2.79E-02	2.93E-06	3.73E-03	0.00E+00	2.10E-02
End of life	Deconstruction, demolition	C1	0.00E+00	0.00E+00	0.00E+00	0.00E+00	0.00E+00	0.00E+00
	Transport	C2	0.00E+00	0.00E+00	0.00E+00	0.00E+00	0.00E+00	0.00E+00
	Waste processing	C3	0.00E+00	0.00E+00	2.35E-01	0.00E+00	0.00E+00	0.00E+00
	Disposal	C4	0.00E+00	0.00E+00	0.00E+00	0.00E+00	0.00E+00	0.00E+00
Potential benefits and loads beyond the system boundaries	Reuse, recovery, recycling potential	D	0.00E+00	0.00E+00	0.00E+00	0.00E+00	0.00E+00	0.00E+00

CRU = Components for reuse;
MFR = Materials for recycling

MER = Materials for energy recovery;
EE = Exported Energy



Scenarios and additional technical information

Scenarios and additional technical information			
Scenario	Parameter	Units	Results
C1 - Deconstruction	When the product reaches its end of life, the installer removes the window or door system from the property prior to replacement. Hand power tools are used to dismantle the Sheerline frames, electricity used to charge power tool batteries, which is considered negligible in comparison with the overall energy demand of building demolition. Therefore, no data are reported for this module.		
	It's assumed as 100% of the product is recovered from demolition site.		
C2 - Transportation	50 km by road has been modelled for module C2 as a typical distance from the demolition to site to the incineration with energy recovery plant. However, end-users of the EPD can use this information to calculate the impacts of a bespoke transport distance for module C2 if required.	Lorry	16 – 32 metric ton
	Transportation distance	km	50
C3 – Waste Processing	In Module C3, the Sheerline products are transported to the recycling and incineration facility. There are no pre-processing activities undertaken before the product components are sent to recycling/incineration centres.		
	According to BRE's PCR 3.2 for EN15804:2019 +A2, the end-of-life scenarios for {window frame, aluminium} and {window frame, PVC/uPVC} stated in Appendix D of the BRE PCR document, closely correspond to those of the Sheerline products, % waste route shows below: <ul style="list-style-type: none"> aluminium (coated/protected): 95% recycle, 5% landfill uPVC: 100% incineration 		
	Aluminium (coated/protected) to recycling	kg	0.726
	uPVC to incineration	kg	0.235
C4 - Disposal	Aluminium (coated/protected) to landfill	kg	0.038
Module D	<p>The product contains 73 % aluminium, 24% uPVC and 3% powder paint. 73% aluminium contains 25.9% of pre-existing secondary content that has been removed from the Module D calculation to avoid the double-counting of environmental benefits.</p> <p>Therefore, the benefits reported in Module D per 1 kg Sheerline product contains 0.51kg as well as the 100% energy recovery from uPVC incineration (0.235kg).</p>		



Interpretation

The bulk of the environmental impacts and primary energy demand are attributed to the manufacturing of Sheerline windows, door and roofing systems product, covered by information modules A1-A3 of EN15804:2012+A2:2019.

This product contains 73 % aluminium, 24% uPVC and 3% powder paint. The chart illustrates the relative contributions of various processes to overall greenhouse gas emissions, measured as global warming potential. It highlights that aluminium production standing out as the most significant contributor. uPVC production contributes moderately. Overall, the chart underscores the importance of material choice and waste management in reducing carbon emissions across the lifecycle.

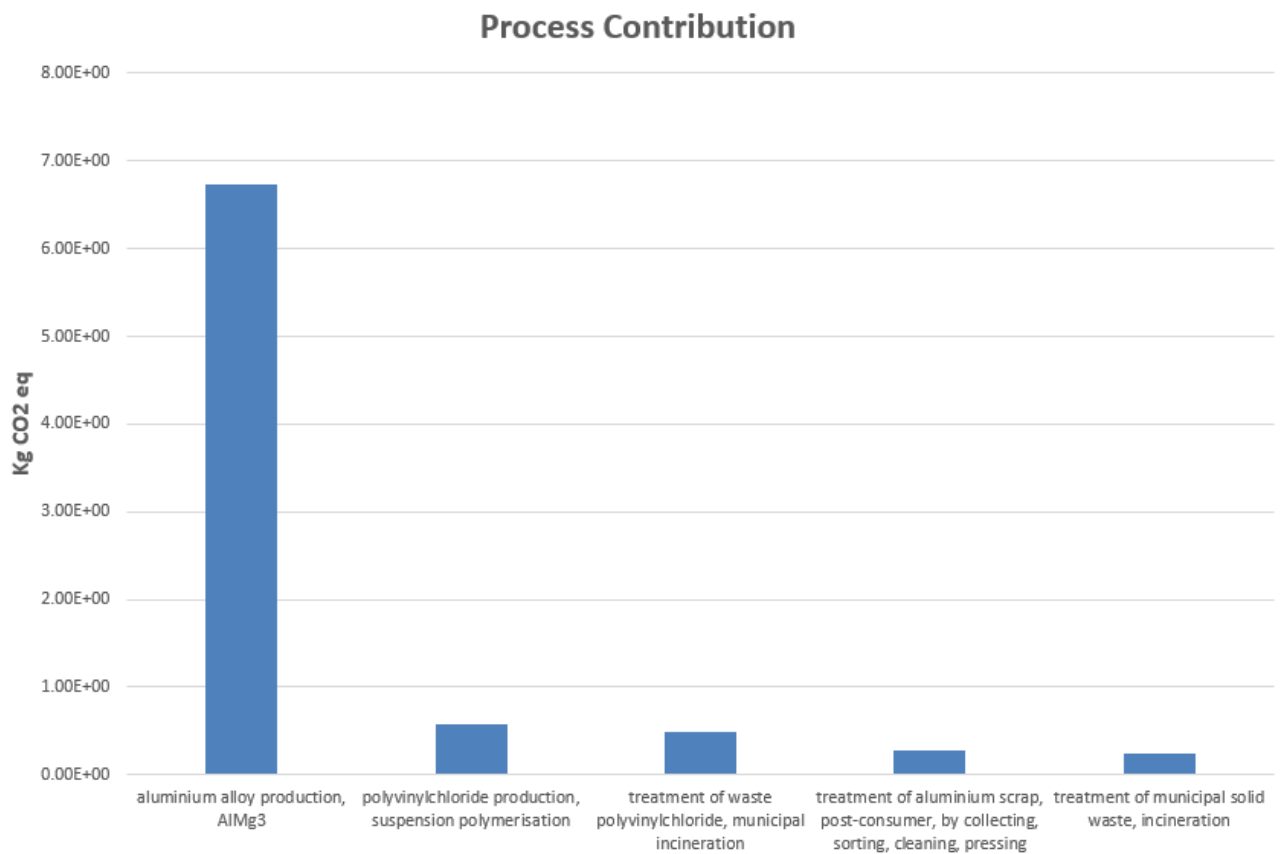

Figure 1: Process Contribution



References

BSI. Sustainability of construction works – Environmental product declarations – Core rules for the product category of construction products. BS EN 15804:2012+A1:2013. London, BSI, 2013.

BSI. Environmental labels and declarations – Type III Environmental declarations – Principles and procedures. BS EN ISO 14025:2010 (exactly identical to ISO 14025:2006). London, BSI, 2010.

BSI. Environmental management – Life cycle assessment – Principles and framework. BS EN ISO 14040:2006. London, BSI, 2006.

BSI. Environmental management – Life cycle assessment – requirements and guidelines. BS EN ISO 14044:2006. London, BSI, 2006.

BSI. Aluminium alloy windows. BS 4873:2016. London, BSI, 2016.

BSI. Enhanced security performance requirements for window assemblies. BS 4873:2016 & PAS 24:2022. London, BSI, 2022.

BSI. Enhanced security aluminium door systems. BS 4873:2016 & PAS 24:2022. London, BSI, 2022.

DEFRA UK statistics on waste. London, Department for Environment, Food & Rural Affairs, 2025
<https://www.gov.uk/government/statistics/uk-waste-data/uk-statistics-on-waste#packaging-waste>