

Measuring the environmental performance of construction materials:

The Green Guide to Specification – Flooring and Internal Partitioning

BREEAM Materials, BRE Global

February 2009



Overview

- Sustainability context and buildings
- LCA and Environmental Profiles Methodology
- The Green Guide to Specification
- Use of the Green Guide – BREEAM and The Code
- Impacts of flooring and internal partitioning

Sustainability – Why are we here?

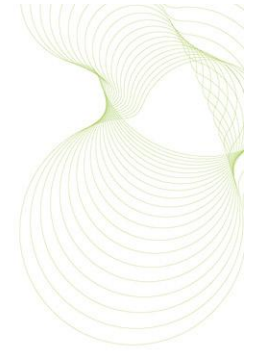

Construction industry and buildings

- Large impacts
 - Construction and demolition waste alone represents 32% of total UK waste (DEFRA)
 - the energy used in constructing, occupying and operating buildings represents approximately 50% of greenhouse gas emissions in the UK. (Environment Agency 2007)
 - Passenger transport vehicles account for a further 15% of CO₂ emissions. (EST)



Sustainability: How does this apply to buildings?

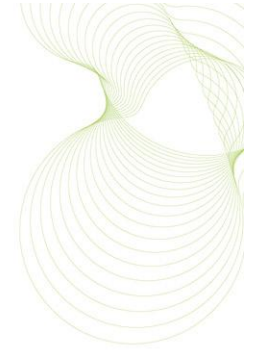

- Sustainability is a complex & political agenda
- Generally no agreed consensus
- Likely to always change depending upon context
- Lots of **Greenwash**
- No single tool for measuring sustainability
- Industry using many tools/methods/systems;
 - Life Cycle Assessment (LCA)
 - BREEAM
 - Code for Sustainable Homes (CSH)
 - Carbon Labelling & Footprinting
 - Whole Life Costing (WLC)
 - Environmental Product Declarations (EPD's)
 - Many others...

Looking at the product level...

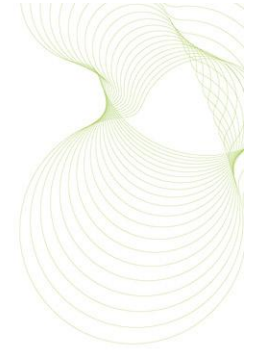

How do we measure environmental performance?

**Life Cycle Assessment
(LCA)**

Life Cycle Assessment (LCA)



Extraction

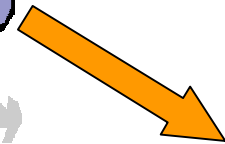

Creation

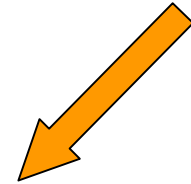
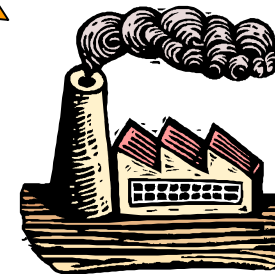

Environmental impacts



Maintenance

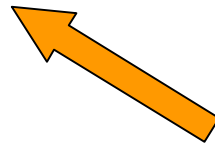

Disposal



How can LCA be used in the Industry?



- To measure existing performance and monitor improvements
- To assess benefits of innovative processes
- To compare materials which offer the similar functions, eg external wall constructions
- To compare building designs over their expected lifetimes
- Used in the BRE Environmental Profiles Methodology
- Applied in tools like The Green Guide to Specification

What is an Environmental Profile?



Measurement of the **environmental performance** of a material, product or system over a set time period.

- Extraction of raw materials & transport (“cradle to gate”)
- Production (“gate to gate”)
- Transport, installation and end of life (“gate to grave”)

Achieved using Life Cycle Assessment (LCA)

Used in BRE 2007 Environmental Profiles Methodology

- **Level playing field for assessing construction products**

Outcome is a Type III Environmental Product Declaration (EPD) compliant with ISO 14025 (externally audited by UKAS)

Environmental Profiles 2008 Impact categories

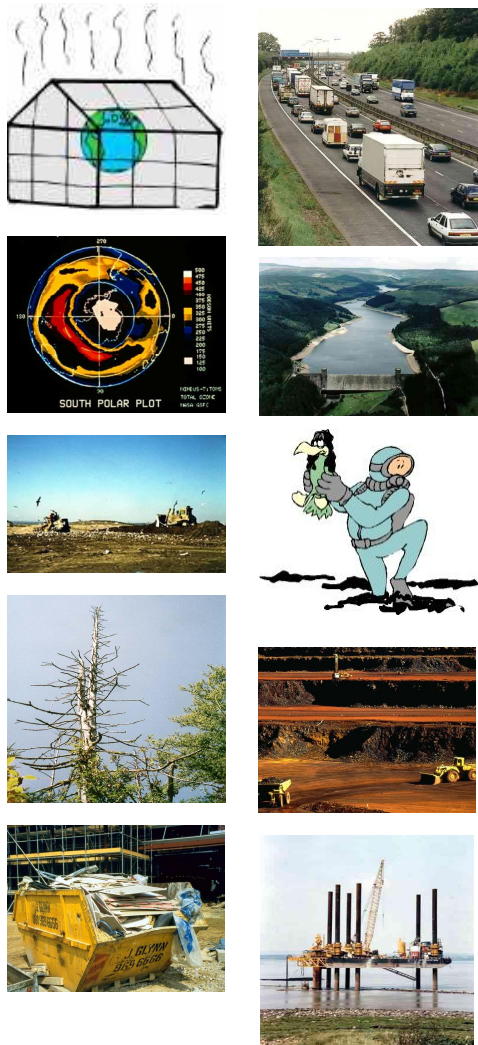
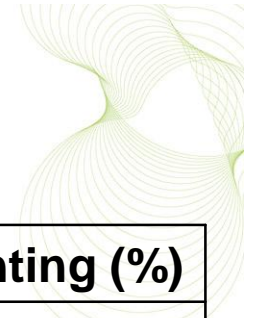

Environmental Issue	Weighting (%)
Climate Change	21.6
Water extraction	11.7
Mineral resource depletion	9.8
Stratospheric ozone depletion	9.1
Human toxicity	8.6
Ecotoxicity to water	8.6
Nuclear waste	8.2
Ecotoxicity to land	8.0
Waste disposal	7.7
Fossil fuel depletion	3.3
Eutrophication	3.0
Photochemical ozone creation	0.20
Acidification	0.05

Derivation of Ecopoints



Issues

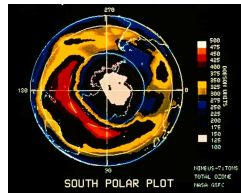
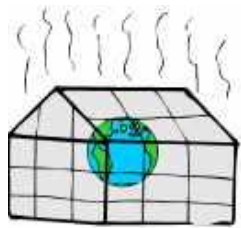

Measurement



Weighting



**E
C
O
P
O
I
N
T
S**

The Environmental Profile – An independent product declaration





Approved Environmental Profile

Characterised and Normalised Data for:
**1 square metre over 60 Year Life: Floor finish: Hard floor coverings:
 Tarkett Sommer Homogeneous IQ Vinyl flooring**

Quality of Data for Certified Material (Data for other constituent materials are available from BRE)

Start Date	1 January 2002
End Date	31 December 2002
Source of Data	Tarkett Sommer
Geography	Sweden
Representativeness	1 Site Representing 100% of Tarkett Sommer's Homogeneous IQ Vinyl Flooring Production
LCA Methodology	BRE Environmental Profiles
Allocation	100% to Product
Date of Data Entry	3 June 2003
Boundary	Cradle to Grave over 60 Year Building Life
Comments	

Issue	Characterised Data	Unit
Climate Change	25	kg CO2 eq. (100yr)
Acid Deposition	0.2	kg SO2 eq.
Ozone Depletion	0.000022	kg CFC11 eq.
Pollution to Air: Human Toxicity	0.32	kg tox.
Pollution to Air: Photochemical Ozone Creation Potential	0.030	kg ethene eq.
Pollution to Water: Human Toxicity	0	kg tox.
Pollution to Water: Ecotoxicity	500	m ³ tox.
Pollution to Water: Eutrophication	0.015	kg PO4 eq.
Fossil Fuel Depletion	0.018	toe
Minerals Extraction	0.02	tonnes
Water Extraction	720	litres
Waste Disposal	0.02	tonnes
Transport Pollution & Congestion: Freight	17	tonne.km

Issue	Normalised Data	UK Citizen's impacts
Climate Change	0.002	12300 kg CO2 eq. (100yr)
Acid Deposition	0.0034	58.9 kg SO2 eq.
Ozone Depletion	0.000077	0.286 kg CFC11 eq.
Pollution to Air: Human Toxicity	0.0035	90.7 kg tox.
Pollution to Air: Photochemical Ozone Creation Potential	0.0012	32.2 kg ethene eq.
Pollution to Water: Human Toxicity	0	0.0117 kg tox.
Pollution to Water: Ecotoxicity	0.0028	178000 m ³ tox.
Pollution to Water: Eutrophication	0.0019	8.01 kg PO4 eq.
Fossil Fuel Depletion	0.0043	4.00 toe
Minerals Extraction	0.004	5.04 tonnes
Water Extraction	0.0017	418000 litres
Waste Disposal	0.0028	7.19 tonnes
Transport Pollution & Congestion: Freight	0.0041	4140 tonne.km
Primary Energy	0.3	GJ
BRE Ecopoints Score	0.24	Ecopoints

Appendix No: 200a Valid From: 16/06/03 Valid To: 15/06/06

Issue No: 1

Signed on behalf of BRE Certification: R.A. Zammit

BRE Certification Ltd, Garston, Watford WD25 9JX, Tel 0 1923 664 930 Fax 0 1923 664003 www.brecertification.co.uk
 This certificate remains the property of BRE Certification Ltd and is issued subject to terms and conditions
 and is maintained updated in force through annual review and verification.
 To check the authenticity of this certificate, please visit our website or contact us.

BRE Global: Certified Environmental Profiles

- Sister company to BRE (previously BRE Certification)
- Data verification process – evidence
- Supports external claims
- Environmental Profiles valid 3 years
- An independent environmental product declaration
- Whole process revolves around:
 - Product manufacture data
 - Data verification (Factory site audit)
 - Data modelling – LCA methodology

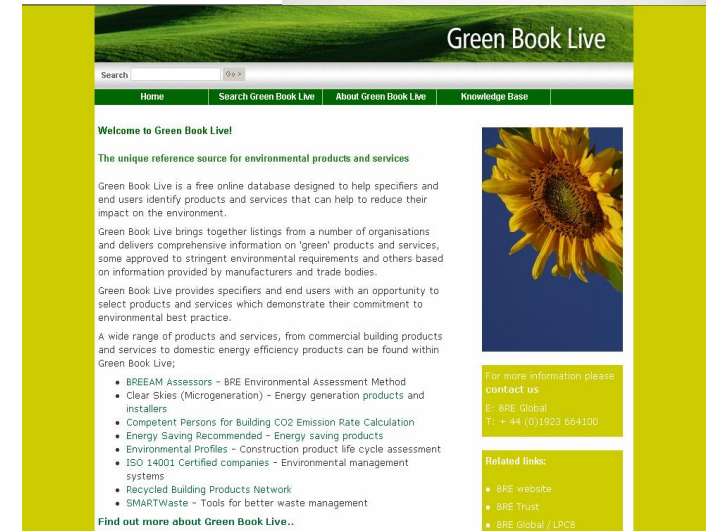
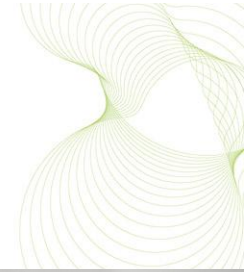

What do you do with an Environmental Profile? Comparison at a building element level

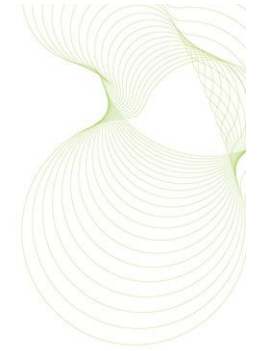

Bricks vs bricks



Wall specifications



Blocks vs blocks



VS

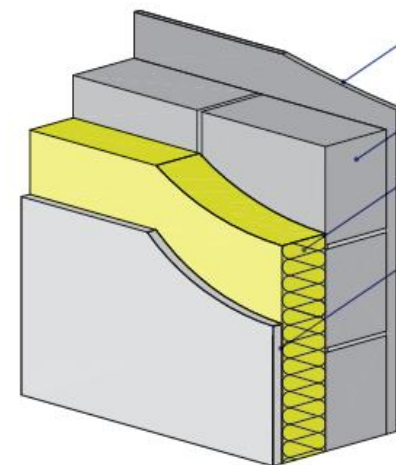

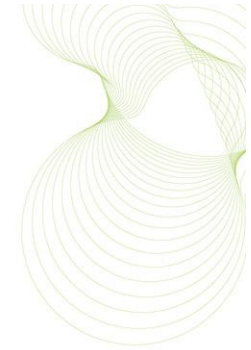

The Green Guide to Specification

- Ecopoints for building materials placed into specifications
- Environmental impacts of building elements
- Based on LCA
- A+ to E rating

www.thegreenguide.org.uk

The screenshot shows the Breglobal website interface for 'THE GREEN GUIDE TO SPECIFICATION'. The header includes the 'breglobal' logo and the title 'THE GREEN GUIDE TO SPECIFICATION'. A navigation menu on the left lists: '< Back to BRE', 'Home', 'Introduction to The Green Guide', 'Sponsors', 'Publications and Tools', 'How the Green Guide was compiled', 'How to use the Green Guide to Specification', 'Register', and 'Login'. The main content area is titled 'Green Guide 2008 ratings' and features a dropdown menu for 'Building type >' set to 'Commercial'. Below this, it prompts the user to 'Please select an element' with several buttons: 'Upper Floor Construction', 'Internal Wall', 'External Wall Construction', 'Insulation', 'Commercial Windows', 'Roof Construction', and 'Landscaping'. A 'CONTACT' box on the right provides contact information: 'E: Green Guide Helpdesk' and 'T: +44 (0)1923 664 462'. The footer contains the copyright notice: '© Copyright BRE 2008 | Terms, Conditions and Privacy policy'.

The Ecopoint and A+ to E ratings

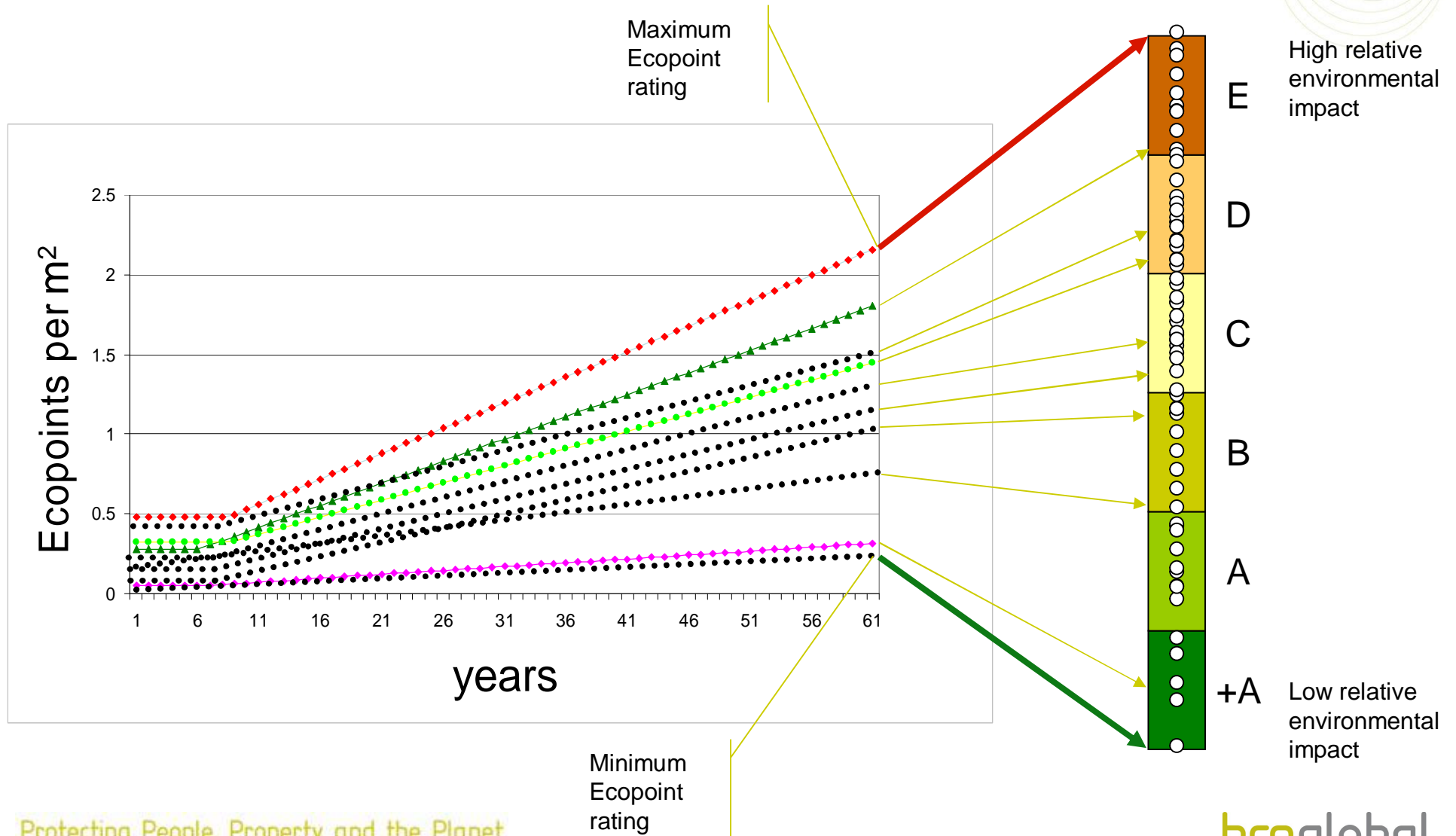
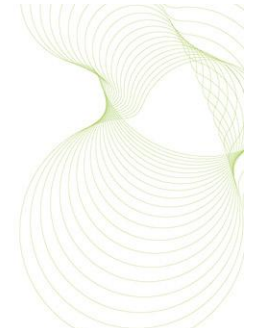

The Green Guide to Specification

- Green Guide update
 - Online & Paper publication

www.thegreenguide.org.uk

- 1500+ generic specifications each with summary Ratings
- Ratings A+ to E
- 13 impact category ratings
- Six building types
- FREE access
- Ongoing development

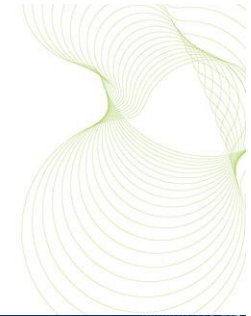

The screenshot shows the website's header with the 'breglobal' logo and the title 'THE GREEN GUIDE TO SPECIFICATION'. A navigation menu on the left includes links for 'Home', 'Introduction to The Green Guide', 'Publications and Tools', 'How the Green Guide was compiled', 'How to use the Green Guide to Specification', and 'Green Guide 2008 Ratings'. The main content area features a 'Welcome to The Green Guide to Specification Online' section, followed by a detailed introduction to the online guide and its purpose. A 'CONTACT' box provides email and phone information, and an 'EXTERNAL LINKS' box points to 'GreenBookLive'. A photograph of a modern building is visible on the right side of the page.



< Back to BRE

Home

Introduction to The Green Guide

Publications and Tools

How the Green Guide was compiled

How to use the Green Guide to Specification

Green Guide 2008 Ratings

Welcome to The Green Guide to Specification Online

Green Guide online provides designers and specifiers with easy-to-use guidance on how to make the best environmental choices when selecting construction materials and components.

In the Green Guide online, building materials and components are assessed in terms of their environmental impact across their entire life cycle - from 'cradle to grave'. This accessible and reliable information will be of great assistance to all those involved in the design, construction and management of buildings as they work to reduce the environmental burden of their properties.

The specifications shown throughout the Green Guide should not, however be used as a basis for on-site construction. They are of generic nature only and are used to illustrate a range of typical materials. Although every effort has been made to ensure that the information given here is accurate, our knowledge and understanding continues to evolve. The Green Guide ratings shown here represent our best efforts to provide objective, helpful guidance to enable the specifier to make more informed choices based on the data and methodologies available at this present time.

The Green Guide online has been developed alongside the printed version which will be published later this year. The Green Guide online offers a flexible and adaptable medium and will be updated on a regular basis.



CONTACT

E: Green Guide Helpdesk
T: +44 (0)1923 664 462
 or via one of our [local offices](#)

EXTERNAL LINKS:

[GreenBookLive](#) - information on all current Certified Environmental Profiles



Building Type?

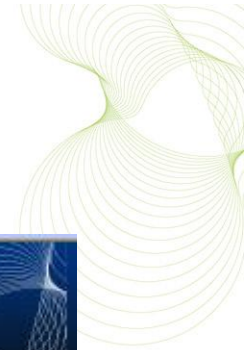

THE GREEN GUIDE TO SPECIFICATION

[< Back to BRE](#)
[Home](#)
[Introduction to The Green Guide](#)
[Sponsors](#)
[Publications and Tools](#)
[How the Green Guide was compiled](#)
[How to use the Green Guide to Specification](#)
[Register](#)
[Login](#)
Green Guide 2008 Ratings

Green Guide 2008 ratings

The Green Guide 2008 ratings can be accessed by following a series of steps to allow you to select the most appropriate range of ratings, starting with the type of building in which the element will sit.

Some ratings apply to more than one building type and this will be stated at element selection stage.

The ratings can be viewed on screen or printed.

Note that ratings are copyright BRE and should not be reproduced in any publicly accessible format without the express permission of BRE. Please email the Green Guide Helpdesk.

Please select a building type

Domestic	Health	Industrial
Commercial	Retail	Education

CONTACT
E: Green Guide Helpdesk
T: +44 (0)1923 664 462

© Copyright BRE 2008 | [Terms, Conditions and Privacy policy](#)



Element?



- [< Back to BRE](#)
- [Home](#)
- [Introduction to The Green Guide](#)
- [Publications and Tools](#)
- [How the Green Guide was compiled](#)
- [How to use the Green Guide to Specification](#)
- [Green Guide 2008 Ratings](#)**

Green Guide 2008 ratings

Building type > **Domestic**

CONTACT
E: Green Guide Helpdesk
T: +44 (0)1923 664 462

Please select an element

- | | | |
|--------------------------|---------------------------|----------------------------|
| Upper Floor Construction | Ground Floor Construction | Internal Wall |
| Domestic Windows | Roofing | External Wall Construction |
| Insulation | Party Wall | Party Floor |
| Landscaping | | |

Element details

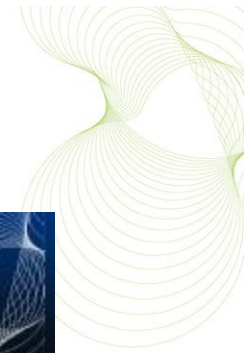

breglobal THE GREEN GUIDE TO SPECIFICATION

< Back to BRE

Home

Introduction to The Green Guide

Sponsors

Publications and Tools

How the Green Guide was compiled

How to use the Green Guide to Specification

Register

Login

Green Guide 2008 Ratings

Green Guide 2008 ratings

Building type > **Domestic**

Category > **External Wall Construction**

External Walls

External wall ratings are the same for the following building types:
Domestic, Health, Commercial, Retail, Industrial, Education

Functional unit for External Walls:
1m² of external wall construction, to satisfy current building regulations, and a U value of 0.3 W/m²K. Where relevant, the specification will also include an internal wall finish.

Variation for retail/industrial
1m² of external wall construction, to satisfy current building regulations, and a U value of 0.3 W/m²K.

Perhaps more than any decision facing the designer, the choice of the external wall specification is subject to the widest range of practical, economic and visual considerations, some of which may be beyond the control of the design team.

External walls can have a significant contribution to the impacts of



CONTACT
E: Green Guide Helpdesk
T: +44 (0)1923 664 462

Sub-Section of Elements



Please select the element type of **External Wall**
Construction ratings you wish to review:

Blockwork Cavity Wall	Rendered or Fairfaced Blockwork Cavity Wall	Brickwork on Framed Construction
Rendered or Fairfaced Blockwork	Cladding on Framed Construction	Cladding on Masonry
Rainscreen Cladding	Insulated Cladding	Insulated Render Systems
Curtainwalling	Loadbearing Precast Concrete	

Element

Sub-Section

Specification ratings



<ul style="list-style-type: none"> < Back to BRE Home Introduction to The Green Guide Sponsors Publications and Tools How the Green Guide was compiled How to use the Green Guide to Specification Register Login <li style="background-color: #92d050;">Green Guide 2008 Ratings 	<p>Green Guide 2008 ratings</p> <p>Building type > Domestic</p> <p>Category > External Wall Construction</p> <p>Sub-category > Loadbearing Precast Concrete</p> <p>Element type > Loadbearing Precast Concrete Systems</p> <table border="1"> <thead> <tr> <th></th> <th>Element number</th> <th>Summary rating</th> </tr> </thead> <tbody> <tr> <td>Brick faced precast concrete cladding panel, insulation, light steel studwork, plasterboard, paint</td> <td>806230679</td> <td>C</td> </tr> <tr> <td>Brick faced precast concrete cladding panel, insulation, medium dense solid blockwork, plasterboard, paint</td> <td>806230687</td> <td>C</td> </tr> <tr> <td>Brick faced precast concrete sandwich panel, plaster skim, paint</td> <td>806530294</td> <td>D</td> </tr> <tr> <td>Imported Chinese granite faced precast concrete cladding panel, insulation, light steel studwork, plasterboard, paint</td> <td>806230688</td> <td>D</td> </tr> <tr> <td>Imported Chinese granite faced precast concrete cladding panel, insulation, medium dense solid blockwork, plasterboard, paint</td> <td>806530022</td> <td>D</td> </tr> <tr> <td>Imported Chinese granite faced precast concrete sandwich panel, plaster skim, paint</td> <td>806530295</td> <td>E</td> </tr> <tr> <td>Limestone faced precast concrete cladding panel, insulation, light steel studwork, plasterboard, paint</td> <td>806260690</td> <td>C</td> </tr> <tr> <td>Limestone faced precast concrete cladding panel, insulation, medium dense solid blockwork, plasterboard, paint</td> <td>806530021</td> <td>D</td> </tr> <tr> <td>Limestone faced precast concrete sandwich panel, plaster skim, paint</td> <td>806530296</td> <td>D</td> </tr> <tr> <td>Reconstructed stone faced precast concrete cladding panel, insulation, medium dense solid blockwork, plasterboard, paint</td> <td>806000023</td> <td>C</td> </tr> <tr> <td>Reconstructed stone faced precast concrete cladding panel, insulation, light steel studwork, plasterboard, paint</td> <td>806260689</td> <td>B</td> </tr> <tr> <td>Reconstructed stone faced precast concrete sandwich panel, plaster skim, paint</td> <td>806530293</td> <td>C</td> </tr> </tbody> </table>		Element number	Summary rating	Brick faced precast concrete cladding panel, insulation, light steel studwork, plasterboard, paint	806230679	C	Brick faced precast concrete cladding panel, insulation, medium dense solid blockwork, plasterboard, paint	806230687	C	Brick faced precast concrete sandwich panel, plaster skim, paint	806530294	D	Imported Chinese granite faced precast concrete cladding panel, insulation, light steel studwork, plasterboard, paint	806230688	D	Imported Chinese granite faced precast concrete cladding panel, insulation, medium dense solid blockwork, plasterboard, paint	806530022	D	Imported Chinese granite faced precast concrete sandwich panel, plaster skim, paint	806530295	E	Limestone faced precast concrete cladding panel, insulation, light steel studwork, plasterboard, paint	806260690	C	Limestone faced precast concrete cladding panel, insulation, medium dense solid blockwork, plasterboard, paint	806530021	D	Limestone faced precast concrete sandwich panel, plaster skim, paint	806530296	D	Reconstructed stone faced precast concrete cladding panel, insulation, medium dense solid blockwork, plasterboard, paint	806000023	C	Reconstructed stone faced precast concrete cladding panel, insulation, light steel studwork, plasterboard, paint	806260689	B	Reconstructed stone faced precast concrete sandwich panel, plaster skim, paint	806530293	C
	Element number	Summary rating																																						
Brick faced precast concrete cladding panel, insulation, light steel studwork, plasterboard, paint	806230679	C																																						
Brick faced precast concrete cladding panel, insulation, medium dense solid blockwork, plasterboard, paint	806230687	C																																						
Brick faced precast concrete sandwich panel, plaster skim, paint	806530294	D																																						
Imported Chinese granite faced precast concrete cladding panel, insulation, light steel studwork, plasterboard, paint	806230688	D																																						
Imported Chinese granite faced precast concrete cladding panel, insulation, medium dense solid blockwork, plasterboard, paint	806530022	D																																						
Imported Chinese granite faced precast concrete sandwich panel, plaster skim, paint	806530295	E																																						
Limestone faced precast concrete cladding panel, insulation, light steel studwork, plasterboard, paint	806260690	C																																						
Limestone faced precast concrete cladding panel, insulation, medium dense solid blockwork, plasterboard, paint	806530021	D																																						
Limestone faced precast concrete sandwich panel, plaster skim, paint	806530296	D																																						
Reconstructed stone faced precast concrete cladding panel, insulation, medium dense solid blockwork, plasterboard, paint	806000023	C																																						
Reconstructed stone faced precast concrete cladding panel, insulation, light steel studwork, plasterboard, paint	806260689	B																																						
Reconstructed stone faced precast concrete sandwich panel, plaster skim, paint	806530293	C																																						

Summary Issue Category Ratings



[< Back to BRE](#)

[Home](#)

[Introduction to The Green Guide](#)

[Sponsors](#)

[Publications and Tools](#)

[How the Green Guide was compiled](#)

[How to use the Green Guide to Specification](#)

[Register](#)

[Login](#)

[Green Guide 2008 Ratings](#)

Green Guide 2008 ratings

Building type > **Domestic**

Category > **External Wall Construction**

Sub-category > **Loadbearing Precast Concrete**

Element type > **Loadbearing Precast Concrete Systems**

Element	Brick faced precast concrete cladding panel, insulation, medium dense solid blockwork, plasterboard, paint
Element Number	806230687
Summary Rating	C
Climate Change	D
Water Extraction	B
Mineral Resource Extraction	A
Stratospheric Ozone Depletion	D
Human Toxicity	A
Ecotoxicity to Freshwater	A+
Nuclear Waste (higher level)	A
Ecotoxicity to Land	D
Waste Disposal	D
Fossil Fuel Depletion	D
Eutrophication	D
Photochemical Ozone Creation	B
Acidification	C

The Use of the Green Guide to Specification



- Architects and building specifiers
- Part of BRE's Environmental Assessment Methods for buildings
 - BREEAM & EcoHomes (BRE)
 - Code for Sustainable Homes (BRE & DCLG)
 - Materials specification credits
 - www.breeam.org

breeam

Protecting People, Property and the Planet



breglobal



What is BREEAM?

- BRE - Environmental Assessment Method
- Voluntary Certification scheme for Buildings (but often specified as part of planning)
- Provides an environmental label for buildings
 - Pass, Good, Very Good, Excellent, Outstanding
- Independent & credible
- Holistic and Issue based – broad range of environmental concerns
- Ensures best environmental practice above regulatory minimum
- Large scope – many different types of buildings assessed
- Used mainly in UK but also growing Internationally

breeam



The Code for Sustainable Homes

- The Sustainable Buildings Task Group (SBTG)
- Set up by DEFRA, DTI, DCLG, EA, EP and others

- Launched April 2007, revised May 2008
- A single national standard for England
- Based on BREEAM - EcoHomes
 - (replaces EcoHomes in England)

- Mandatory rating for all new homes in England (May 08) and now for Wales too!



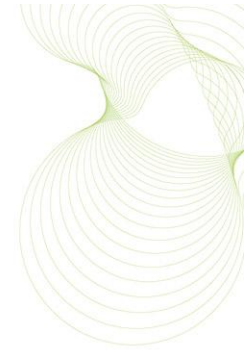

Materials Specification

- One of the many issues assessed in BREEAM and The Code
- Credits available - variable
- Whole life environmental impact
- Key building elements assessed
- Green Guide to Specification
 - Ratings A+ to E
 - www.thegreenguide.org.uk

The screenshot shows the Breglobal website interface for 'THE GREEN GUIDE TO SPECIFICATION'. The header includes the 'breglobal' logo and the title 'THE GREEN GUIDE TO SPECIFICATION'. A navigation menu on the left lists: '< Back to BRE', 'Home', 'Introduction to The Green Guide', 'Sponsors', 'Publications and Tools', 'How the Green Guide was compiled', 'How to use the Green Guide to Specification', 'Register', 'Login', and 'Green Guide 2008 Ratings'. The main content area is titled 'Green Guide 2008 ratings' and features a 'Building type >' dropdown menu set to 'Commercial'. Below this, it says 'Please select an element' and displays several buttons: 'Upper Floor Construction', 'Internal Wall', 'External Wall Construction', 'Insulation', 'Commercial Windows', 'Roof Construction', and 'Landscaping'. A 'CONTACT' box in the top right corner provides contact information: 'E: Green Guide Helpdesk' and 'T: +44 (0)1923 664 462'.

- Higher scores for better rated elements
- Code – Minimum D rated specifications
- Based on LCA and Environmental Profiles Methodology
- Bespoke ratings – Certified Environmental Profiles

How are internal finishes assessed within BREEAM and The Code?



- Points available within the materials specification credit
 - floor finishes
 - Internal walls/partitions

Elements assessed	Non Domestic schemes											Domestic			
	BREEAM											EcoHomes (2006)	Multi-Residential	Code For Sustainable Homes	
	Bespoke	Offices (design)	Offices (fit out)	Retail (design)	Retail (fit out)	NEAT (NHS)	Healthcare	Prisons	Schools	Courts	Industrial				Further Education
Upper Floors	Y	Y		Y		Y	Y	Y	Y	Y		Y	Y	Y	Y
Ground Floors													Y		Y
External walls	Y	Y		Y		Y	Y	Y	Y	Y	Y	Y	Y	Y	Y
Roofs	Y	Y		Y		Y	Y	Y	Y	Y	Y	Y	Y	Y	Y
Floor Finishes	Y		Y		Y	Y	Y		Y	Y		Y		Y	
Windows	Y	Y		Y		Y	Y		Y	Y		Y	Y	Y	Y
Internal walls/partitions	Y		Y		Y	Y	Y		Y	Y		Y	Y	Y	Y
Hard landscaping	Y	Y		Y		Y	Y	Y	Y	Y	Y	Y	Y	Y	
Boundary protection	Y	Y		Y		Y	Y	Y	Y	Y	Y	Y	Y	Y	

Green Guide performance for internal finishes: Floor finishes



- Currently Flooring ratings undergoing consultation following feedback from Industry
- New 2008 Green Guide ratings imminent
- Currently BREEAM & Code use 2002 Green Guide ratings
 - **1999 Environmental profiles methodology**
 - **Generic A to C ratings**
- 2002 Green Guide ratings
 - **Floor finishes have highest range of impacts**
 - **~ 40% whole building impact**



2002 Green Guide performance for internal finishes: Floor finishes



- **2002 Green Guide ratings**
- Hard floor finishes
 - Linoleum, ceramic / marble / cork tiles, Timber = **A**
 - PVC = **B** (high toxicity levels)
 - Synthetic rubber = **C** (higher climate change impacts)
- Soft floor finishes
 - Wool, nylon carpet = **A**
 - Foam backed carpets = **C** (high climate change impact)
- This may all change with new methodology!
 - New data from TA's
 - Industry has changed
 - Different impact categories
 - More detailed groupings of flooring types
 - Stronger focus on service lives and maintenance

2008 Green Guide performance for internal finishes: Internal walls / partitions



- Framed partitions
 - **Best performing (A+):** softwood framed and timber stud
 - *Lower climate change impacts*
 - **Steel stud, hardwood framed and timber cassette panels = A**
 - *Higher climate change impact*
- Masonry partitions
 - **Range of specifications and ratings**
 - **Fairfaced brick/block and glass blocks perform well**
 - **Thick precast concrete panels performs poorly**
 - **Rating depends on finish**
 - *Plasterboard has higher impact than plaster finish*
 - *Plasterboard has high climate change and water extraction impacts*



Conclusions

- Sustainability becoming increasingly important for the construction industry
- LCA and Environmental Profiles are tools for assessing environmental performance
- The Green Guide to Specification is a useful tool for architects and specifiers
- Green Guide increasingly being used in the UK due to BREEAM and The Code for Sustainable Homes



Any Questions?

Thank you

Tel: 01923 664462
breeam@bre.co.uk

www.thegreenguide.org.uk

www.breeam.org